



# **INCORPORATED VILLAGE OF SEA CLIFF**

**OFFICE OF THE VILLAGE OF SEA CLIFF BUILDING DEPARTMENT  
300 SEA CLIFF AVE SEA CLIFF N.Y. 11579 PHONE (516) 671-0080**

## **Notice of Review**

3/3/21

**TO:**  
**PROPERTY OWNER:** Michael & Jennifer Keiler  
**PROPERTY ADDRESS:** 19 Marden Ave.  
**SECTION/ BLOCK/ LOT:** 21/61/133

**APPLICATION NO:** 12286  
**APPLICATION RECV'D:** 3/3/2021  
**ZONE:** Residence B

**DESCRIPTION:** The applicant proposes to construct a pool

**The Proposed Construction does not comply with the following Village of Sea Cliff Code Section(s):**

**§ 115-12 Size and location.**

*A. All swimming pools shall be located at the rear or side yard of any premises and shall be set back at least 10 feet from the nearest street, road or highway and at least 10 feet from the nearest property line, except that in Residence C or D Districts[1] every swimming pool shall be set back at least 15 feet from any rear lot line.*

*[1]Editor's Note: The zone designations are established in Ch. 138, Zoning.*

The applicant proposes to construct a pool 5ft from the property line where a minimum of 10ft is required.

**§ 107-4 Review required.**

*[Amended 10-7-1996 by L.L. No. 1-1996; 12-10-2018 by L.L. No. 7-2018; 5-11-2020 by L.L. No. 3-2020]*

*Site plan review, as provided herein, shall be required for the following, and the Planning Board shall approve, approve with modifications or disapprove applications, as follows:*

*E. Any substantial change in topography. For purposes of this section, any change in topography in excess of one foot in height or elevation, at any point or over any ten-foot linear area, in any direction, shall be considered a substantial change.*

The applicant proposes to construct a pool.

  
**Shane Dommin**  
**Village of Sea Cliff Building Department**

**Note; If the proposed construction does not comply with the Village Code, applicant may apply to the Zoning Board of Appeals for relief, within 60 days hereof. If the proposed construction requires Planning Board approval, an application to the Planning Board may be made. All plans are subject to the Building Codes of New York State.**



# INCORPORATED VILLAGE OF SEA CLIFF

## OFFICE OF THE VILLAGE OF SEA CLIFF BUILDING DEPARTMENT

300 SEA CLIFF AVE, P.O. BOX 340, SEA CLIFF, NY 11579 TEL 516-671-0080 FAX 516-671-6508

### BUILDING PERMIT

APPLICATION ID # 12284 APPLICATION DATE 3/1/21 PERMIT # \_\_\_\_\_

PROPERTY ADDRESS: 19 MARDEN AVENUE, SEA CLIFF SECT: 21 BLOCK 61 LOT 133

Owner: MICHAEL & JENNIFER KEILER

Address: 19 MARDEN AVENUE City: SEA CLIFF State: NY Zip: 11579

Phone: 516.729.0470 (Mike) Cell: 516.729.1824 (Jen) Email: radiokreb@gmail.com

Applicant: (if applicant is different from owner state relationship to owner)

Address: SAME AS ABOVE City: \_\_\_\_\_ State: \_\_\_\_\_ Zip: \_\_\_\_\_

Phone: \_\_\_\_\_ Cell: \_\_\_\_\_ Email: \_\_\_\_\_

Architect: (LANDSCAPE) TERRA VERDE / DANIEL GRELLER

Address: 76 HILLSIDE LANE City: SYOSSET State: NY Zip: 11791

Phone: 516.306.0602 Cell: \_\_\_\_\_ Email: DANIEL@LANDSCAPETVLA.COM

Contractor: SWIM CLEAN, INC. / MARK E. McLAUGHLIN

Address: 185 GLEN HEAD ROAD City: GLEN HEAD State: NY Zip: 11545

Phone: 516.759.7665 Cell: 516.250.9128 Email: mclauglind@gmail.com

Plumber:

Address: \_\_\_\_\_ City: \_\_\_\_\_ State: \_\_\_\_\_ Zip: \_\_\_\_\_

Phone: \_\_\_\_\_ Cell: \_\_\_\_\_ Email: \_\_\_\_\_

Electrician: JONATHAN BLIND ELECTRIC, INC.

Address: 12A BAY BEACH AVENUE City: BAYVILLE State: NY Zip: 11709

Phone: \_\_\_\_\_ Cell: 516.477.9784 Email: BLINDELECTRIC@GMAIL.COM

Other/Mechanical:

Address: \_\_\_\_\_ City: \_\_\_\_\_ State: \_\_\_\_\_ Zip: \_\_\_\_\_

Phone: \_\_\_\_\_ Cell: \_\_\_\_\_ Email: \_\_\_\_\_

A/C, Boiler, etc Model# \_\_\_\_\_

A/C, Boiler, etc Model# \_\_\_\_\_

**PROPOSED WORK:** Be as detailed as possible describing anything that is not going to be specifically provided for in plans or other supporting documents such as number of plumbing fixtures, new services, i.e. gas, water, electric, number of new branch circuits or anything else billable by permit. Billable permit items are listed in Village Code Chapter 142-A as a pdf. Link. The building dept. is responsible for assessing permit fees.

BUILD A 600 SQ FT INGROUND FREE FORM VINYL SWIMMING POOL WITH STEPS; 3 1/2' TO 6' DEEP WITH 140,000 BTU HEAT PUMP

\_\_\_\_\_  
\_\_\_\_\_  
\_\_\_\_\_



# INCORPORATED VILLAGE OF SEA CLIFF

## OFFICE OF THE VILLAGE OF SEA CLIFF BUILDING DEPARTMENT

300 SEA CLIFF AVE. P.O. BOX 340, SEA CLIFF, NY 11579 TEL 516-671-0080 FAX 516-671-6508

### BUILDING PERMIT

Cost of Improvement: \$ 29,725.00

**Owner:** Deposits and says that they are the owner(s) in fee of the Premises, that the work proposed to be done upon the said Premises shall be completed in accordance with the approved application and accompanying plans, and that all the statements herein are true to the deponents own knowledge.

Owner Signature: Micha Ken

Owner Signature: James Ken

Date: 3/1/2021 Jennifer Gerrity Notary: JENNIFER GERRITY  
NOTARY PUBLIC, State of New York  
No. 01GE6393557  
Qualified in Nassau County  
Commission Expires 06/17/2023

Contractors must submit proof of current insurance (C-105.2 or U-26.3 for compensation and DB-120.1 for disability or DB-155 for disability) as required by NY State. Form CE-200 may be submitted if exempted. Nassau County requires licensing and liability insurance for residential work. Proof of these are also required of contractors prior to the issuance of the permit

#### OFFICIAL USE

#### FEES

<b>Application Fee</b>	\$ 75 paid 3/1/21
<b>Permit Fees</b>	
Building	_____
Plumbing	_____
Electrical	_____
Mechanical	_____
Certificate	_____
Other	_____
Total Permit Fees	\$ _____

#### REQUIRED CERTIFICATES

- Cert of Occupancy
- Cert of Approval
- Cert of Completion
- Cert of Compliance
- Cert of Tenancy
- Letter in Lieu

Approved by \_\_\_\_\_ Examined for approval on \_\_\_\_\_

**New State Law Requires:** Site visits by the Building Department prior to the issuance of any permit. Changes in project elements or design shall not be made until such changes are approved and documented with the Building Department.

**Village Code Requires:** Zoning variances become invalid if authorized work has not begun within six (6) months of Building Department Approval. Extensions may be applied for to the Zoning Board. (138-1304). Building Permits expire twelve (12) months after the approval. Two (2) subsequent six (6) month extensions may be applied with approval of the Building Department and payment of fees. Additional approvals require application (48-15)

ZONING BOARD OF APPEALS \_\_\_\_\_  
PLANNING BOARD  (check one)

-----x  
IN THE MATTER OF THE APPLICATION OF  
Michael Keiler

APPLICATION

Village of Sea Cliff.  
-----x

Proposing to install 510 square foot pool

1. Name of applicant: Michael Keiler

2. Applicant's address: 19 Marden Ave

3. If the applicant is not an owner of the property which is the subject of this application, state the relationship of the applicant to the owner(s):

4. The property which is the subject of this application is located at: 19 Marden Ave, Village of Sea Cliff, N. Y. and is also known as Section 21, Block 61, Lot(s) 133 on the Nassau County Land and Tax Map.

5. The full name and residence address of all owners of the property (if applicant is not the sole owner) is:

Jennifer Keiler

6. The property is located in the B zoning district of the Village of Sea Cliff.
7. The subject property is located on the east side of Marden (street).
8. The date on which the owner(s) acquired the property was 9/12/07.
9. The approximate dimensions of the property are 88 feet by 170 feet, and the total acreage of property is ~~88~~ .05 acres.
10. The property is presently used for residence
11. Are there existing buildings on the property? 1 of 1
12. Are there any outstanding village taxes on the property?  
no If so, for what years? \_\_\_\_\_
13. The applicant or owner(s) wish to make use of the property for the purpose of: residence
14. The Building Department of the Village of Sea Cliff denied an application for a building permit on 3/3/21
15. The proposed construction use of the property does not comply with the following sections of the Village Code: 107-4
- \_\_\_\_\_
- \_\_\_\_\_
- \_\_\_\_\_

16. This is an application for:

\_\_\_\_\_ an appeal

\_\_\_\_\_ a variance

\_\_\_\_\_ a special permit

X other (describe): site plan review

17. Description of the problem, or reasons for this application, that support the request for relief:

(Note to Applicant - this information is particularly important, and must constitute a complete statement of the grounds for the relief which you are seeking. You may use additional sheets of paper if necessary to provide a complete response)

enjoyment

---

---

---

---

---

18. Has any previous application been made to the Zoning Board of Appeals or Planning Board for the relief sought in this application, or relief similar to that sought in this application? Yes If so, attach a description of each such prior application, including the date the application was made, the date of the determination by the Zoning Board of Appeals or Planning Board, and a summary of the determination by the Zoning Board of Appeals or Planning Board.

19. Has any previous application been made to the Zoning Board of Appeals or Planning Board for any other relief with respect to the property which is the subject of this application? no  
If so, attach a description of each such prior application, including the date the application was made, the date of the determination by the Zoning Board of Appeals or Planning Board, and a summary of the determination of the Zoning Board of Appeals or Planning Board.
20. Are there any outstanding violation notices affecting the subject premises? no
21. Are there any pending court proceedings involving the subject premises? no
22. The undersigned applicant states under penalty of perjury that the foregoing statements and information, and all statements and information contained in papers submitted herewith, are true, correct and complete, to best of the signer's knowledge.

Name of applicant: Michael Keiler  
Signature of applicant: Michael Keiler  
Title of signatory: owner  
Date: 5/14/21

AFFIDAVIT OF APPLICANT

STATE OF NEW YORK) SS:

COUNTY OF NASSAU )

The undersigned, being duly sworn, deposes and says that deponent has read the foregoing application subscribed by applicant, and knows the contents thereof, and that the contents of the application are true of the deponent's personal knowledge, except as to the matters stated to be upon information and belief, as to which matters deponent believes the contents to be true.

If the applicant is a corporation, the deponent is an officer thereof, to wit the \_\_\_\_\_, and is authorized by the Board of Directors of the corporation to execute this application on behalf of the corporation.

If the applicant is a partnership, the deponent is a general partner thereof, and has authority to execute this application in the name of the partnership.

If the applicant is a limited liability company, the deponent is member thereof, and has authority to execute this application in the name of the company.

Michael Keiler

Print Name

M. Keiler

Signature

Sworn to before me this 14<sup>th</sup>  
day of May 2021



JENNIFER GERRITY  
NOTARY PUBLIC, State of New York  
No. 01GE6393557  
Qualified in Nassau County  
Commission Expires 06/17/2023



AFFIDAVIT OF OWNER(S)

(To be completed only if the applicant is not the sole owner)  
(All owners must sign either as owner or applicant)

STATE OF NEW YORK) SS:

COUNTY OF NASSAU )

MICHAEL KEILER being duly sworn, deposes and says that (s)he is the owner of the property known as 19 MARDEN AVENUE in the Village of Sea Cliff. No other person is an owner of the said property except as described in the attached application. The undersigned hereby acknowledges that the applicant herein is authorized to submit this application to the Village of Sea Cliff on behalf of the owner(s) of the subject property.



Sworn to before me on this 11<sup>th</sup> day of February 2021.



**DEBORAH GAUSSA**  
NOTARY PUBLIC, STATE OF NEW YORK  
No. 01GA6074829  
QUALIFIED IN NASSAU COUNTY  
MY COMMISSION EXPIRES MAY 20, 2022

STATE OF NEW YORK) SS:

COUNTY OF NASSAU )

JENNIFER KEILER being duly sworn, deposes and says that (s)he is the owner of the property known as 19 MARDEN AVENUE in the Village of Sea Cliff. No other person is an owner of the said property except as described in the attached application. The undersigned hereby acknowledges that the applicant herein is authorized to submit this application to the Village of Sea Cliff on behalf of the owner(s) of the subject property.

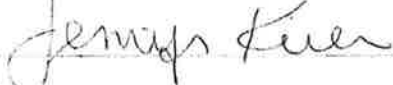

Sworn to before me on this 11<sup>th</sup> day of February 2021.



**DEBORAH GAUSSA**  
NOTARY PUBLIC, STATE OF NEW YORK  
No. 01GA6074829  
QUALIFIED IN NASSAU COUNTY  
MY COMMISSION EXPIRES MAY 20, 2022

ZONING BOARD OF APPEALS \_\_\_\_\_  
PLANNING BOARD X (check one)  
VILLAGE OF SEA CLIFF

In the Matter of the Application of

Michael Keiler

DISCLOSURE  
AFFIDAVIT  
General Municipal Law  
Section 809

STATE OF NEW YORK) COUNTY OF NASSAU )

ss: Michael Keiler, being duly sworn, deposes and says:

1. I am the (applicant with respect to) (owner of the premise which are the subject of) the attached application.
2. I make this affidavit for the purposes of complying with the requirements of General Municipal Law Section 809.
3. No officer of the State of New York, and no officer or employee of the County of Nassau, the Town of North Hempstead or the Village of Sea Cliff, and no party officer of any political party, has an interest in the attached application within the meaning of General Municipal Law Section 809, except as stated hereinafter (if none, state "NONE"):

<u>Name</u>	<u>Address</u>	<u>Position</u>	<u>Nature of Interest</u>
<u>none</u>			

Michael Keiler  
Signature

Sworn to before me this 14th  
day of May 2021.

Jennifer Gerrity

JENNIFER GERRITY  
NOTARY PUBLIC, State of New York  
No. 01GE6393557  
Qualified in Nassau County  
Commission Expires 06/17/2023



**Incorporated Village of Sea Cliff**  
**Office of the Superintendent of Buildings**

Sea Cliff Village Hall, 300 Sea Cliff Ave., Sea Cliff, New York 11579

**Inspection Authorization**

I hereby authorize the members of the Zoning Board and/or Planning Board, the Superintendent of Buildings, and Legal Counsel to the Zoning Board and/or Planning Board to enter upon and inspect my property prior to the Zoning Board and/or Planning Board rendering a determination on this application.

Homeowner: \_\_\_\_\_

Date: \_\_\_\_\_

*Mrs. Kai*  
5/14/21

NOTES:  
PLAN BASED ON SURVEY PROVIDED BY  
CHARLES E. BRYANT JR.  
DATED JULY 8, 1965

DRAWN  
DG  
CHECKED  
DG  
APPROVED  
DG

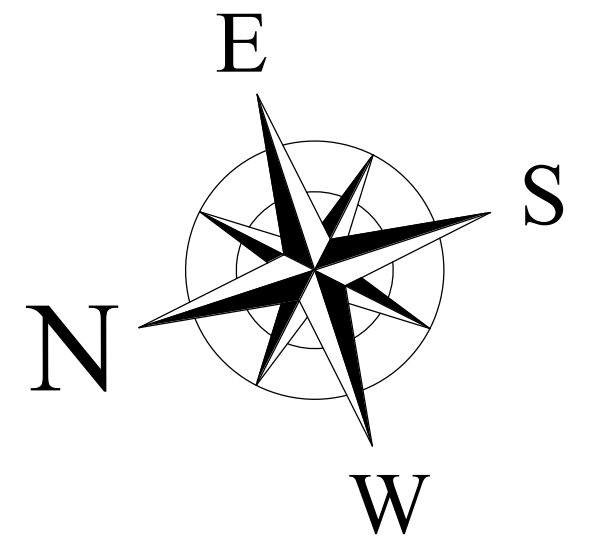

PROJECT:  
**KEILER  
RESIDENCE**  
19 MARDEN AVE  
SEA CLIFF, NY 11579  
SEC. 21 BLK 61 LOT 133



DATE	CHECKED	REVISION
3/8/21	DG	ADJUST PATIO TO 5' FROM PROPERTY LINE

## POOL SITE PLAN

DATE  
11-20-2020  
SCALE  
1/8"=1'-0"  
PROJ. NO.

DRAWING NUMBER  
**S-1**

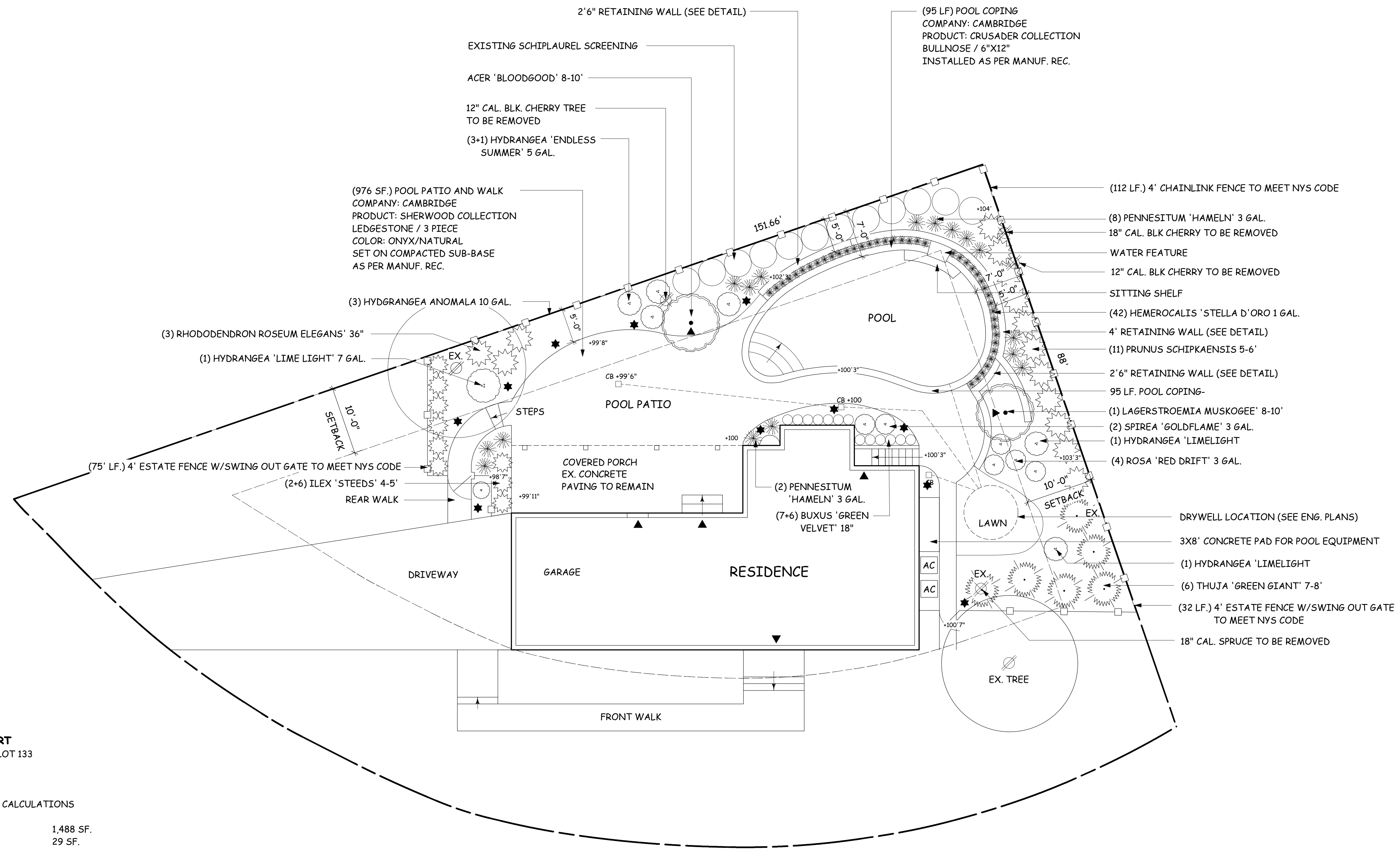

### ZONING DATA CHART

SECTION 21 BLOCK 61 LOT 133

LOT AREA : 10,586 SF.

### PERCENTAGE COVERAGE CALCULATIONS

**EXISTING**  
HOUSE: 1,488 SF.  
STAIRS: 29 SF.  
DRIVEWAY: 890 SF.  
FRONT WALK: 325 SF.  
COVERED PORCH: 342 SF.  
**TOTAL AREA: 3,074 SF.**

**PROPOSED**  
POOL: 510 SF.  
POOL PATIO/WALKS: 976 SF.  
POOL EQU. PAD: 24 SF.  
**TOTAL AREA: 1,510 SF.**

**PROPOSED/EXISTING-**  
TOTAL AREA: 4,584 SF./10,586

PERCENT COVERAGE= 43.30%

### DRAINAGE CALCULATIONS

TOTAL SF.= 976  
COEFFICIENT= 1  
RAINFALL= 3"  
TOTAL= 244 CU/FT.  
DRY-WELL REQUIRED  
(1) 8'DIA. X 6'DEEP= 253.44 CU/FT.  
TOTAL CAPACITY 253.44 CU/FT.

### TREES TO BE REMOVED

18" CAL. BLK CHERRY  
12" CAL. BLK CHERRY  
18" CAL. SPRUCE  
12" CAL. BLK CHERRY

### LIGHTING

◀ (2) ACCENT LIGHT- WAC 5011  
★ (11) PATH LIGHT- KICHLER PYRAMID 2700K  
15807 LED PATH LIGHTTTZT

**HM ENGINEERING P.C.**  
P.O. Box 914  
EAST NORTHPORT, NY 11731  
TEL: 516-476-5392  
EMAIL: HMARNIKA@OPTONLINE.NET

February 22, 2021

Incorporated Village of Sea Cliff  
Building Department  
300 Sea Cliff Avenue  
P.O. Box 340  
Sea Cliff, N.Y. 11579

Dear Sir/Madam:

This is to certify that the drainage facilities to be used exclusively for the construction of a swimming pool on the premises of:

Keiler Residence  
19 Marden Avenue  
Sea Cliff, N.Y. 11579

will not require draining because the pool is constructed with a vinyl liner. The pool water will be continuously recirculated through the filter and will be reused from year to year. The drainage from the filter backwash will be piped to a drywell located on the subject lot and will not interfere with the public water supply system, existing sanitary facilities, adjoining property owners, public highways or private roads.

Sincerely,

HM Engineering P.C.

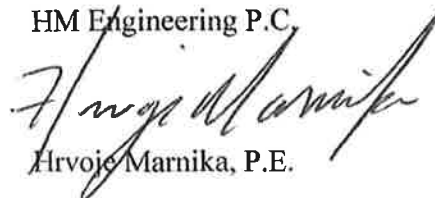

Hrvoje Marnika, P.E.



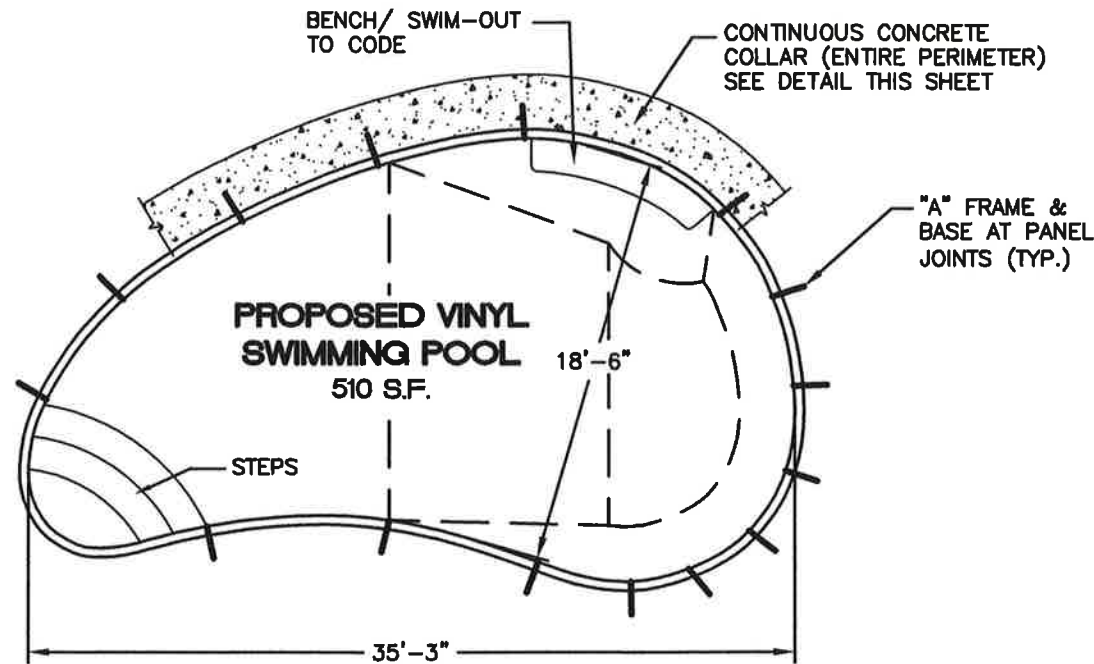

**POOL PLAN**  
NOT TO SCALE

NOTE:  
THIS IS A NON-DIVING POOL.

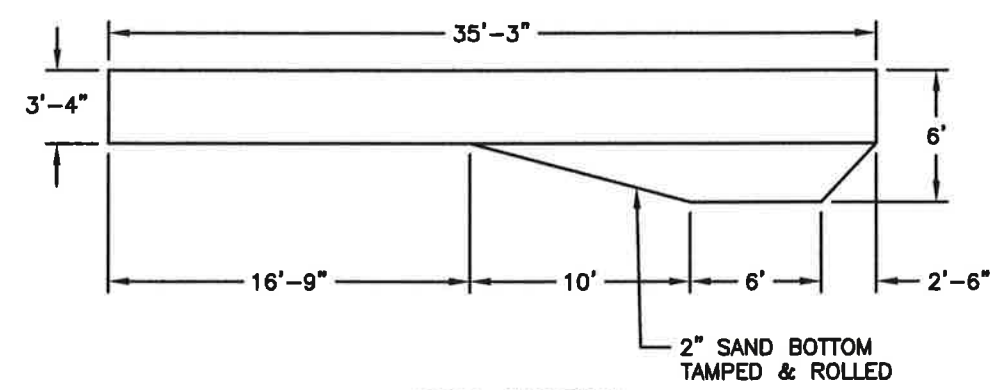

**POOL SECTION**  
NOT TO SCALE

GENERAL NOTE:  
ALL MANUFACTURED ITEMS AND CONSTRUCTION SHALL COMPLY WITH THE 2020 RESIDENTIAL CODE OF NYS, INCLUDING THE SPECIFICATIONS IN SECTION R326.

- NOTES:
1. POOL AND PROPERTY TO CONFORM TO 2020 NYS UNIFORM FIRE PREVENTION AND BUILDING CODE, VILLAGE OF SEA CLIFF CODE AND 2017 NATIONAL ELECTRIC CODE.
  2. POOL SHALL CONFORM TO ANSI/ APSP/ ICC 5 STANDARDS R326.3.1.
  3. SECTION R326.7 POOL ALARM REQUIRED.
  4. ENTRAPMENT PROTECTION REQUIRED SECTION R326.5.
  5. POOL SHALL COMPLY WITH BARRIER REQUIREMENTS SECTION R326.4.
  6. POOL SHALL COMPLY WITH 2020 ENERGY CONSERVATION CONSTRUCTION CODE OF NYS SECTION R403.10: POOLS AND PERMANENT SPA ENERGY CONSUMPTION (MANDATORY).  
SECTION R403.10.1 HEATERS  
SECTION R403.10.2 TIME SWITCHES  
SECTION R403.10.3 COVERS
  7. SLOPE PATIO SURFACE 1/4" PER FOOT (MIN.) AWAY FROM POOL.
  8. LOCATION OF PROPOSED SWIMMING POOL AND POOL EQUIPMENT BY OTHERS. LOCATION TO COMPLY WITH LOCAL ZONING REQUIREMENTS.
  9. BACKFILL MATERIAL TO BE FREE DRAINING GRANULAR MATERIAL (NO CLAY OR LARGE ROCKS).
  10. FILL POOL WITH WATER PRIOR TO BACKFILLING.
  11. POOL TO REMAIN PERMANENTLY FILLED.
  12. ALL DRAIN COVERS TO MEET ALL REQUIREMENTS OF THE VIRGINIA GRAEME BAKER (VGB) POOL AND SPA SAFETY ACT.
  13. NO DIVING EQUIPMENT PERMITTED.
  14. CONTRACTOR SHALL VERIFY SOIL BEARING LOADS PRIOR TO INSTALLATION OF POOL.
  15. THIS PLAN IS FOR CONSTRUCTION ON PROPERTY AT 19 MARDEN AVENUE, SEA CLIFF, N.Y. 11579 ONLY.
  16. HM ENGINEERING, P.C. SHALL NOT BE RESPONSIBLE FOR CONSTRUCTION MEANS, METHODS, TECHNIQUES OR PROCEDURES UTILIZED BY THE CONTRACTOR, NOR FOR THE SAFETY OF THE PUBLIC OR CONTRACTOR'S EMPLOYEES, OR FOR THE FAILURE OF THE CONTRACTOR TO CARRY OUT THE WORK IN ACCORDANCE WITH THIS PLAN.
  17. SUCTION OUTLETS SHALL BE DESIGNED AND INSTALLED IN ACCORDANCE WITH ANSI/APSP/ICC 7.
  18. NO SURCHARGE ALLOWED WITHIN 4' OF SHALLOW END AND 6' OF DEEP END.

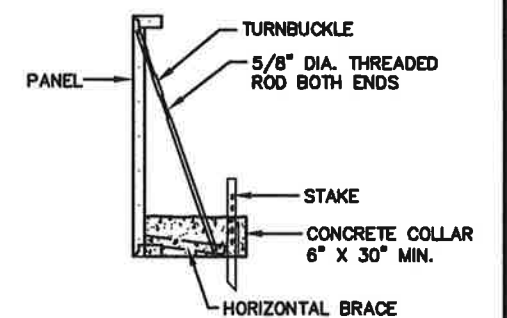

**ALTERNATE "A" FRAME DETAIL**  
NOT TO SCALE

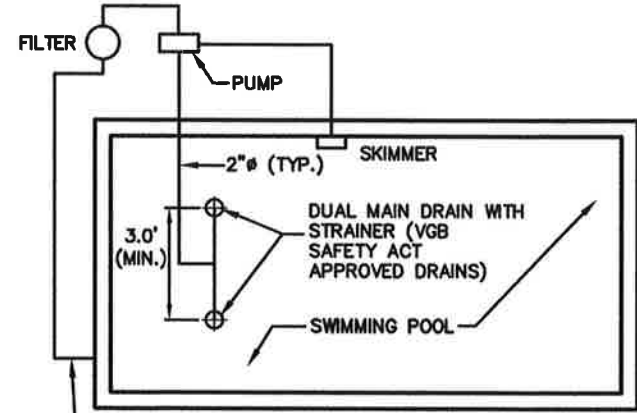

**MAIN DRAIN PIPING SCHEMATIC**  
NOT TO SCALE

NOTE:  
DRAWING CONFORMS TO ANSI/ APSP-7 SUCTION ENTRAPMENT AVOIDANCE CODES.

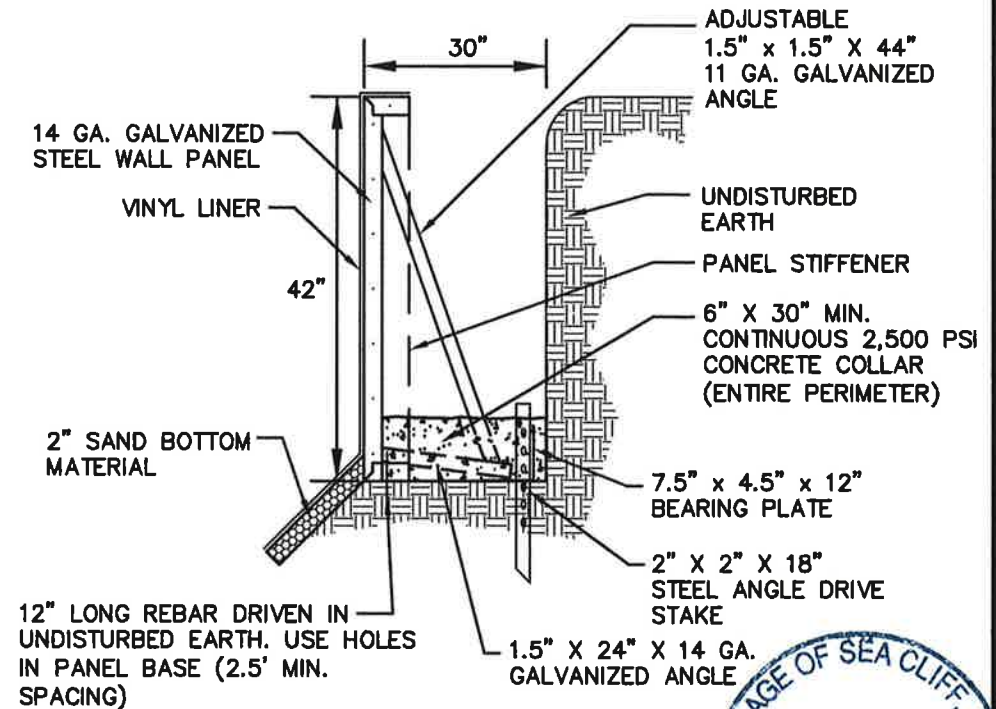

**WALL SECTION & "A" FRAME DETAIL**  
NOT TO SCALE

- NOTES:
1. BACKFILL MATERIAL TO BE SAND, GRAVEL OR OTHER NON-EXPANSIVE MATERIAL.
  2. VERTICAL STIFFENERS TO BE PROVIDED EVERY 4' ON CENTER.
  3. TOP CHANNEL TO BE A 5" WIDE FLANGE.

PREPARED FOR:  
KEILER RESIDENCE  
19 MARDEN AVENUE  
SEA CLIFF, N.Y. 11579  
*Handwritten signature and date 04/09/21*  
VOID WITHOUT RAISED SEAL AND BLUE SIGNATURE

APRIL 09, 2021 - UPDATE POOL DIMENSIONS, REDUCE POOL AREA FROM 600 SF TO 510 SF & REVISE DRYWELL SIZE

NOTE:  
THESE PLANS ARE AN INSTRUMENT OF SERVICE AND ARE THE PROPERTY OF HM ENGINEERING P.C.. UNAUTHORIZED ALTERATIONS OR ADDITIONS TO THESE DOCUMENTS ARE A VIOLATION OF SECTION 7209 OF THE NEW YORK STATE EDUCATION LAW. INFRINGEMENTS WILL BE PROSECUTED.

**HM ENGINEERING, P.C.**

P.O. BOX 914, EAST NORTHPORT, NY 11731  
Tel: (516) 476-5392 Fax: (631) 980-7671 Email: hmarnika@optonline.net

DATE:	02/22/2021
SCALE:	AS SHOWN
SHEET:	1 OF 2
RESIDENTIAL SWIMMING POOL PLAN	



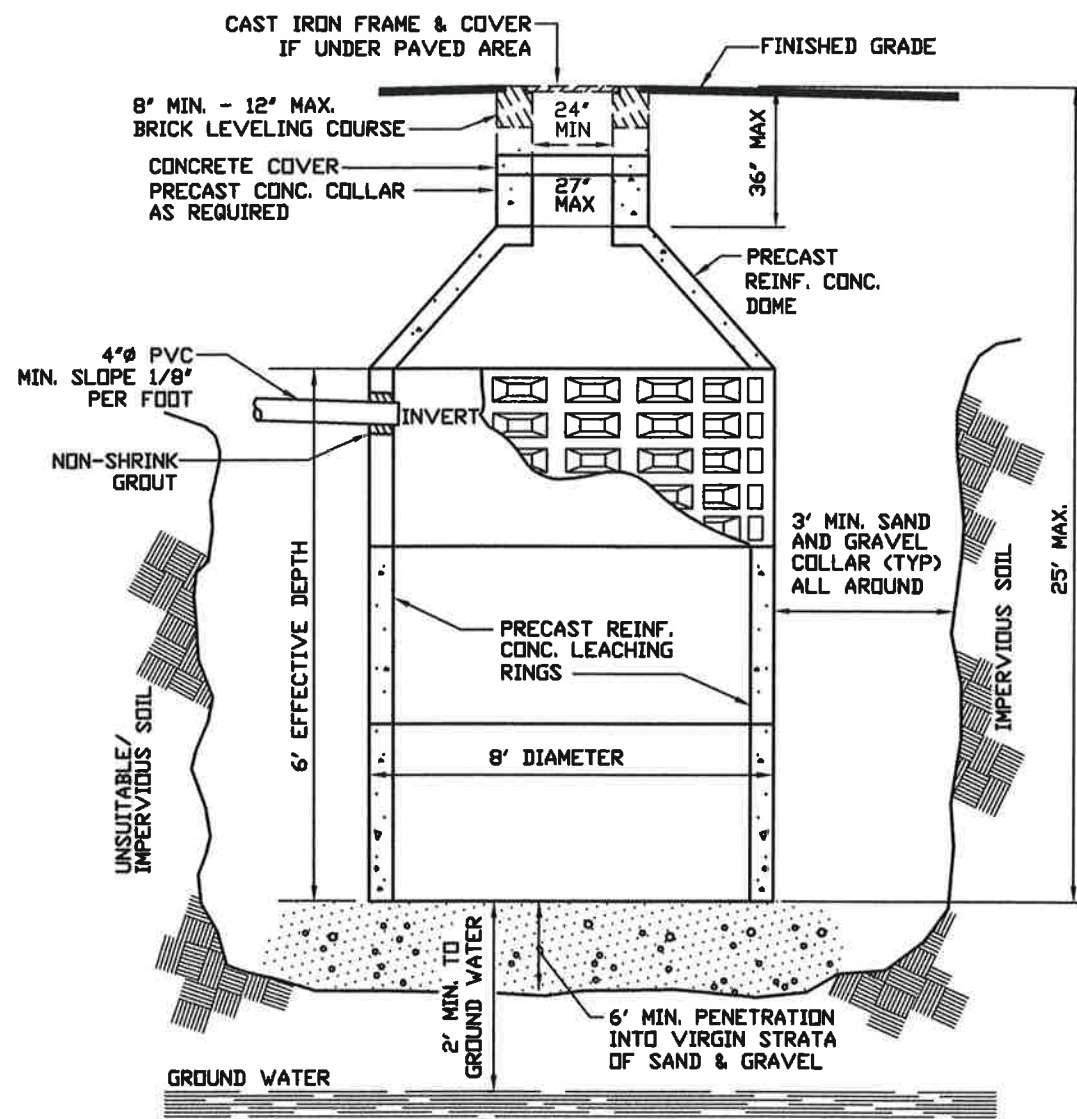

**DRAINAGE POOL DETAIL**  
NOT TO SCALE

**NOTES:**

1. UNSUITABLE MATERIAL SHALL BE REMOVED UNDER LEACHING POOL UNTIL 6' MINIMUM PENETRATION INTO VIRGIN STRATA SAND AND GRAVEL AND BACKFILLED WITH SAND AND GRAVEL TO BOTTOM OF BASIN.
2. AS AN ALTERNATIVE TO THE DOME TOP, A FLAT SLAB CAN BE SUBSTITUTED WITH APPROVAL OF THE ENGINEER.
3. LOCATION OF DRAINAGE POOL TO BE DETERMINED BY OTHERS.
4. ALL DRAINAGE PIPES MUST BE PROVIDED WITH A MINIMUM 2'-0" COVER.
5. COLLAR IS NOT REQUIRED WHEN RATEABLE MATERIAL EXISTS FOR FULL DEPTH.
6. THE MATERIAL USED FOR COLLARING SHALL BE COMPRISED OF SAND AND GRAVEL CONTAINING LESS THAN FIFTEEN (15) PERCENT FINE SAND, SILT AND CLAY. SILT AND CLAY FRACTIONS ARE NOT TO EXCEED (5) PERCENT.

**DRYWELL CALCULATION:**

POOL CAPACITY = 18,000 GAL.  
 DRYWELL SIZED TO ACCOMMODATE 10% OF POOL VOLUME  
 18,000 GAL. X 10% = 1,800 GAL. OR 241 C.F. REQUIRED  
 PROVIDE 8' DIA. X 6' EFF. DEPTH DRYWELL  
 DRYWELL CAPACITY = 1,892 GAL. (253 C.F.)

PREPARED FOR:  
 KEILER RESIDENCE  
 19 MARDEN AVENUE  
 SEA CLIFF, N.Y. 11579

*H. Marnika*  
 04/09/21  
 VOID WITHOUT RAISED SEAL AND BLUE SIGNATURE



APRIL 09, 2021 - UPDATE POOL DIMENSIONS, REDUCE POOL AREA FROM 600 SF TO 510 SF & REVISE DRYWELL SIZE

NOTE: THESE PLANS ARE AN INSTRUMENT OF SERVICE AND ARE THE PROPERTY OF HM ENGINEERING P.C.. UNAUTHORIZED ALTERATIONS OR ADDITIONS TO THESE DOCUMENTS ARE A VIOLATION OF SECTION 7209 OF THE NEW YORK STATE EDUCATION LAW. INFRINGEMENTS WILL BE PROSECUTED.

**HM ENGINEERING, P.C.**

P.O. BOX 914, EAST NORTHPORT, NY 11731  
 Tel: (516) 476-5392 Fax: (631) 980-7671 Email: hmarnika@optonline.net

DATE: 02/22/2021  
 SCALE: NOT TO SCALE  
 SHEET: 2 OF 2

**DRYWELL PLAN AND CALCULATIONS**





MARDEN AVE

$\Delta = 81^{\circ} 38' 32''$

$L = 188.09$

LAFAYETTE AVE.  
N 71-06-10E  
3.29

S 0-51-04 N

R = 132.0'

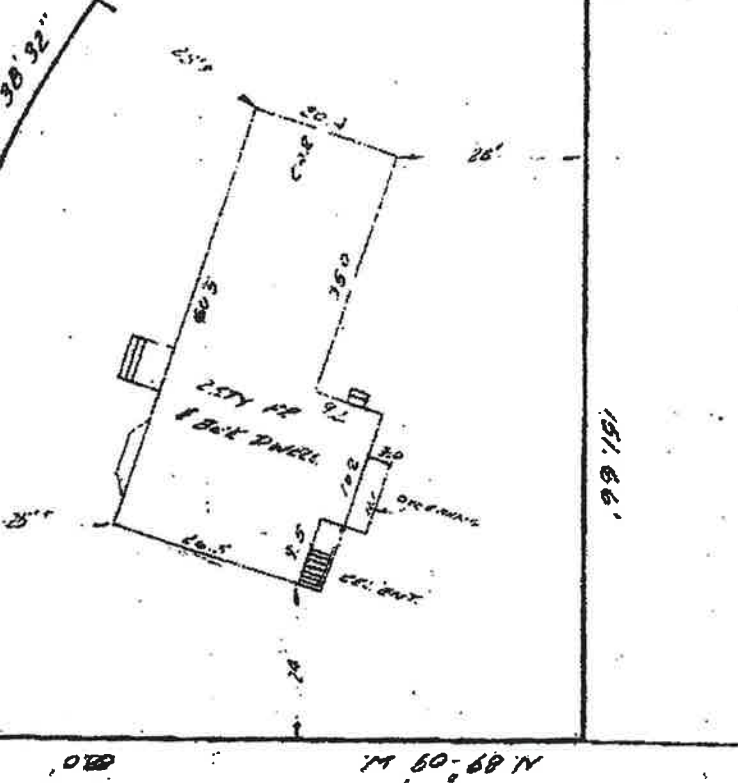

MAP OF PART OF LOT 133 SEC 21 BLK 61  
NASSAU Co. TAX MAP - MAP OF THE  
CARPENTER PROPERTY SEA CLIFF N Y  
SCALE 1" = 20'

MAR 15, 1965  
APR 28, 1965 JULY 8, 1965

GUARANTEED TO SECURITY TITLE & GUARANTY CO  
& ROOSEVELT SAVINGS & LOAN ASSOC.

Permit #103/  
C.O.# 463

*Charles E. Bryant Jr.*  
CHARLES E. BRYANT JR.  
LIC. SURVEYOR  
SEA CLIFF, N. Y.

JOB #14. SEC 21 BLK 61

59080

19 Marden Ave  
Sea Cliff











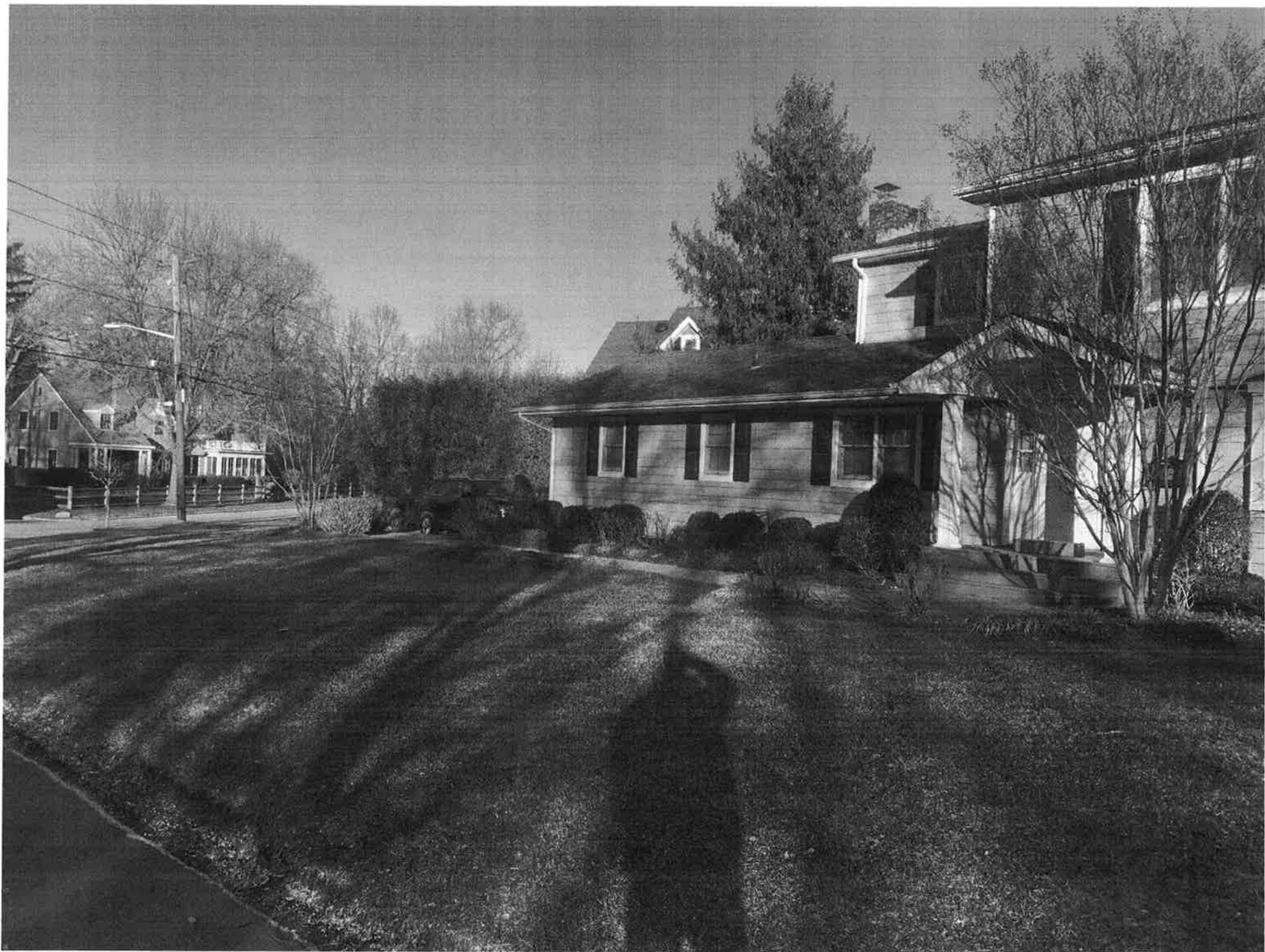











## 5" COLONIAL WALL

The 5" Colonial Wall is offered in hard-split rock face finish. It features a double-sided face, available in three face lengths and includes corner units (packaged on a combined pallet). The tongue and groove locking mechanism will ensure a solid connection and helps facilitate rapid installation. It is perfect for a wide range of applications from garden and free-standing walls to fire pits. There is also a prepackaged Colonial Pier to add the finishing touch to your wall.

**nicolock**  
PAVING STONES • RETAINING WALLS • OUTDOOR LIVING  
paver-shield

Wall Systems



5" Colonial Wall | Color: Granite City Blend



# 5" COLONIAL WALL

	PRODUCT	SIZE	SF / PALLET	PCS / PALLET	LBS / PALLET
A	LARGE	5" x 16" x 9"	35	18	3,548
B	MEDIUM	5" x 12" x 9"		30	
C	SMALL	5" x 9" x 9"		30	
D	CORNER UNIT	5" x 16" x 9"		12	

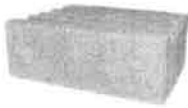

5" x 16" x 9"



5" x 12" x 9"



5" x 9" x 9"



Corner: 5" x 16" x 9"



Adobe Blend



Bluestone\*

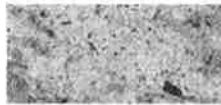

Chesapeake Blend\*

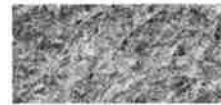

Crab Orchard Blend



Fire Island Blend

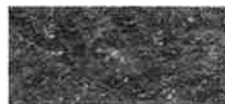

Golden Brown Bend



Granite City Blend

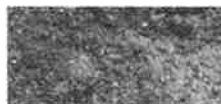

Oyster Blend



Travertina\*



Westchester Blend

\*Premium Colors

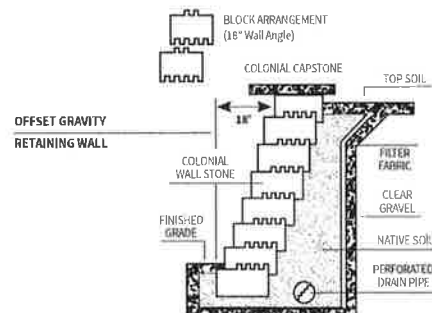
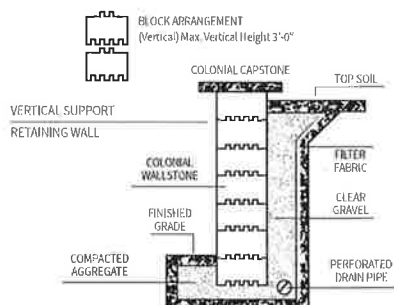

**NOTE:** All walls over 2' in height or as required by local code should be designed by a licensed professional engineer. All measurements are nominal. Variance in square footage or linear footage coverage can be up to 5% depending on joint width. The possible occurrence of efflorescence does not affect the structural integrity of the product. Efflorescence is a normal occurrence in concrete products and will dissipate with normal weathering. The use of concrete as a base or setting bed may increase the possibility of efflorescence.



Corporate HQ: 640 Muncy Avenue | Lindenhurst | NY | 11757 | 631.669.0700 | nicolock.com





**KEILER SHORT FORM DECISION**  
**(as authorized by Village Code §1302.1)**

At a meeting of the Board of Appeals of the Village of Sea Cliff, New York, on April 27, 2021, on motion duly made by Mr. Mozer, seconded by Mr. D'Errico, and adopted unanimously, the Board, having duly considered the matters brought forth at the original public hearing, documentation timely submitted to the Board, and other matters properly within the consideration of this Board and discussed the subject application, rendered the following short-form determination:

1. Michael and Jennifer Keiler, 19 Marden Avenue, Sea Cliff, New York, to construct a swimming pool, which construction requires a variance of Village Code §115-12, in that the pool will be located 5 feet from a property line, where a minimum of 10 feet is required. Premises are designated as Section 21, Block 61, Lot 133 on the Nassau County Land and Tax Map.
2. The applicants are the record owners of the subject premises.
3. The requested relief is classified as a Type II action under SEQRA, which requires no environmental review.
4. The Board provided notice of the application to the Nassau County Planning Commission in accordance with the requirements of the agreement between the Village and the Planning Commission.
5. The relief requested in the application is granted provided that (a) the construction shall conform to the plans submitted with the application, (b) applicants shall comply with all requirements of the Village Code and the Building Department, and (c) all work is performed, and all approvals obtained, within the timeframe provided in Village Code §138-1304.

TURNER CLAUDE & ALLISON  
OR CURRENT OWMER  
23 MARDEN AVE  
SEA CLIFF, NEW YORK 11579

~~INC VILLAGE OF SEA CLIFF  
OR CURRENT OWMER  
LAFAYETTE AVE  
SEA CLIFF, NEW YORK 11579~~

~~FUTHL ROYAL P & ALISON S~~  
OR CURRENT OWMER  
18 MARDEN AVE  
SEA CLIFF, NEW YORK 11579

*Richard Bubbico*

LYNCH BRIAN S & CAMPBELL JOANN C  
OR CURRENT OWMER  
50 HAWTHORNE RD  
SEA CLIFF, NEW YORK 11579

EDER D FLAIM & F  
OR CURRENT OWMER  
81 LAFAYETTE AVE  
SEA CLIFF, NEW YORK 11579

CULLEN PAUL M & SUZANNE R  
OR CURRENT OWMER  
85 LAFAYETTE AVE  
SEA CLIFF, NEW YORK 11579

CARBALLAL JAMES & MARY D  
OR CURRENT OWMER  
80 LAFAYETTE AVE  
SEA CLIFF, NEW YORK 11579

~~DEGNO ANGELO J & ALFREY D & HOMMEL AMY L~~  
OR CURRENT OWMER  
22 MARDEN AVE  
SEA CLIFF, NEW YORK 11579

*Amy Hommel*

SCHIDLOVSKY GEORGE & KATHERINE  
OR CURRENT OWMER  
86 LAFAYETTE AVE  
SEA CLIFF, NEW YORK 11579

~~REDDAN HAROLD & LISA~~  
OR CURRENT OWMER  
79 LAFAYETTE AVE  
SEA CLIFF, NEW YORK 11579

*Michael Robertson*

~~KEILER MICHAEL & JENNIFER  
OR CURRENT OWMER  
19 MARDEN AVE  
SEA CLIFF, NEW YORK 11579~~

*Keiler -*

*19 Marden Ave*





NASSAU COUNTY CLERK'S OFFICE  
ENDORSEMENT COVER PAGE

Recorded Date: 09-17-2007  
Recorded Time: 1:19:13 p

Record and Return To:  
SPANO ABSTRACT SERVICE CORP  
370 OLD COUNTRY ROAD  
STE 100  
GARDEN CITY, NY 11530

Liber Book: D 12316  
Pages From: 451  
To: 453

Control  
Number: 1348  
Ref #: RE 003956  
Doc Type: D01 DEED

Location:	Section	Block	Lot	Unit
OYSTER BAY (2824)	0021	00061-00	00136	

Consideration Amount: 725,000.00

LS001

Taxes Total	2,900.00
Recording Totals	124.00
Total Payment	3,024.00

THIS PAGE IS NOW PART OF THE INSTRUMENT AND SHOULD NOT BE REMOVED  
MAUREEN O'CONNELL  
COUNTY CLERK



2007091701348

RECEIVED IN THIS CONDITION

SP-20560-88

Standard N.Y. B.U.L. Form 5002

(Bargain and Sale Deed with Covenant against Grantor's Act)

CONSULT YOUR LAWYER BEFORE SIGNING THIS INSTRUMENT - THIS INSTRUMENT SHOULD BE USED BY LAWYERS ONLY

201  
3  
725000

THIS INDENTURE, made the 12<sup>th</sup> day of September, in the year two thousand and seven

BETWEEN

HELEN HUSSONG, as surviving tenant of a tenancy by the entirety with Richard Hussong, dec., residing at 19 Marden Avenue, Sea Cliff, New York

party of the first part, and

MICHAEL KEILER and JENNIFER KEILER, his wife, Residing at 19 Bryant Road, Glen Cove, New York

party of the second part,

WITNESSETH, that the party of the first part, in consideration of Ten Dollars and other valuable consideration paid by the party of the second part, does hereby grant and release unto the party of the second part, the heirs or successors and assigns of the second part forever,

Incorporated

ALL that certain plot, piece or parcel of land, with the buildings and improvements thereon erected, situate, lying and being in the Village of Sea Cliff, Town of Oyster Bay, County of Nassau and State of New York, known as and by lots 33 and 32 on a certain map entitled, "Map of Carpenter Property at Sea Cliff, Queens County, N.Y., surveyed 8/23/93 by William E. Hawxhurst, Surveyor", and filed in the Office of the Clerk of the County of Queens on 4/12/1894 under the File No. 1213, Nassau County No. 213, Case No. 1712, which ~~was~~ said parts of lots, when taken together are more particularly bounded and described as follows:

S  
21  
B  
61  
L  
136

BEGINNING at a point on the southerly side of Lafayette Avenue distant 3.29 feet easterly from the intersection of the southerly side of Lafayette Avenue and the southeasterly side of Marden Avenue;

RUNNING THENCE South 0 degrees 51 minutes 00 seconds West, a distance of 151.66 feet;

THENCE North 89 degrees 09 minutes 00 seconds West 88 feet to the easterly side of Marden Avenue;

THENCE northerly and northeasterly, as measured, along the easterly and southeasterly sides of Marden Avenue, along the arc of a circle having a radius of 132 feet, a distance of 188.09 feet to the southerly side of Lafayette Avenue;

THENCE North 71 degrees 06 minutes 10 seconds East along the southerly side of Lafayette Avenue 3.29 feet to the point or place of BEGINNING.

SAID premises being commonly known as #19 Marden Avenue, Sea Cliff, New York.

Nassau County Land and Tax Map: Section 21 Block 61 and Lot 136

Being and intended to be the same premises as described in deed dated 8/17/65, recorded 8/19/65 in Liber Book 7418 Page 389.

TOGETHER with all right, title and interest, if any of the party of the first part in and to any streets and roads abutting the above described premises to the center lines; TOGETHER with the appurtenances and all the estate and rights of the party of the first part in and to said premises; TO HAVE AND TO HOLD the premises herein granted unto the party of the second part, the heirs or successors and assigns of the party of the second part forever. AND the party of the first part covenants that the party of the first part has not done or suffered anything whereby the said premises have been encumbered in any way whatever, except as aforesaid. AND the party of the first part, in compliance with Section 13 of the Lien Law, covenants that the party of the first part will receive consideration for this conveyance and will hold the right to receive such consideration as a trust fund to be applied first for the purpose of paying the cost of the improvement and will apply the same first to the payment of the cost of the improvement before using any part of the total of same for any other purpose. The word "party" shall be construed as if it read "parties" whenever the sense of this indenture so requires.

IN WITNESS WHEREOF, the party of the first part has duly executed this deed the day and year first above written.

IN PRESENCE OF:

HELEN HUSSONG



STATE OF NEW YORK,  
COUNTY OF NASSAU  
On the 12<sup>th</sup> day of September in the year 2007,  
before me, the undersigned, personally appeared  
HELEN HUSSONG

personally known to me or proved to me on  
the basis of satisfactory evidence to be the individual(s)  
whose name(s) is (are) subscribed to the within instrument  
and acknowledged to me that he/she/they executed the same  
in his/her/their capacity(ies), and the individual(s) on the instrument,  
the individual(s), or the person on behalf  
of which the individual(s) acted, executed the instrument.

  
Don Frenkel III  
Notary Public, State of New York  
No. 2106000233  
Queens, NY Nassau County  
Commission Expires January 17, 2010

STATE OF \_\_\_\_\_  
On the \_\_\_\_\_ day of \_\_\_\_\_ in the year \_\_\_\_\_  
before me, the undersigned, personally appeared

personally known to me or proved to me on  
the basis of satisfactory evidence to be the individual(s)  
whose name(s) is (are) subscribed to the within instru-  
ment and acknowledged to me that he/she/they  
executed the same in his/her/their capacity(ies), and  
that by his/her/their signature(s) on the instrument, the  
individual(s), or person on behalf of which the  
individual(s) acted, executed the instrument.

[Add the following if the acknowledgment is  
taken outside NY State]  
And that the said individual made such appearance  
the undersigned in the [insert the city or other political  
subdivision and the State or country or other place  
Acknowledgment was taken].

RECEIVED IN  
THIS CONDITION

STATE OF \_\_\_\_\_ COUNTY OF \_\_\_\_\_  
On this \_\_\_\_\_ day of \_\_\_\_\_ in the year \_\_\_\_\_  
before me, the undersigned, a Notary Public in and for  
said State, personally appeared

\_\_\_\_\_ the  
subscribing witness to the foregoing instrument, with whom  
I am personally acquainted, who, being by me duly sworn,  
did depose and say that he/she/they reside(s) in

[If the place of residence is in a city, include the street and  
street number, if any, thereof]  
that he/she/they know(s)

to be the individual described in and who executed the  
foregoing instrument, that said subscribing witness was present  
and saw said  
the

execute the same, and that said witness at the same time sub-  
scribed his/her/their name(s) as a witness thereto.

[Add the following if the acknowledgment is taken  
outside NY State]  
and that the subscribing witness made such appearance before  
the undersigned [insert the city or other political subdivision  
and the State or country or other place the proof was taken].

STATE OF \_\_\_\_\_, COUNTY OF \_\_\_\_\_  
On the \_\_\_\_\_ day of \_\_\_\_\_ in the year \_\_\_\_\_  
before me personally came

to me known, who, being by me duly sworn, did depose  
and say that he resides at

that he is the  
of  
the corporation described in and which executed the  
foregoing instrument, that he knows the seal of said  
corporation, that the seal affixed to said instrument is  
such corporate seal, that it was so affixed by order of

board of directors of said corporation, and that he  
signed in pursuance thereto by like order.

**Bargain and Sale Deed**  
WITH COVENANT AGAINST GRANTOR'S ACTS  
SP-20560-N

HELEN HUSSONG

TO

MICHAEL KEILER and JENNIFER KEILER,  
His wife

SECTION 21  
BLOCK 61  
LOT 136  
COUNTY OR TOWN Nassau  
STREET ADDRESS 19 Marden Avenue  
Sea Cliff, NY

RETURN BY MAIL TO:

Spano Abstract Service Corp  
370 Old Country Road  
Suite 100  
Garden City, NY 11530